

Taps for inserts



EG M **6H mod**



 **HSS-E Co5**



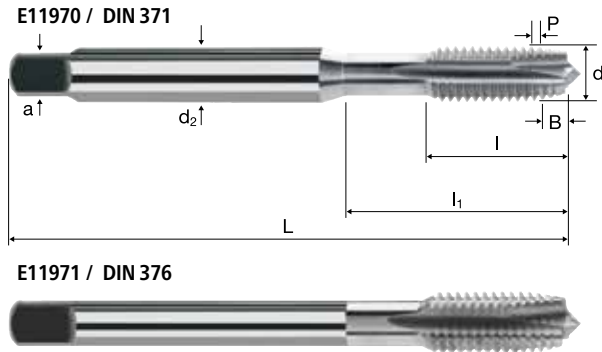

 **Form B**



Rm < 850 **Al** Aluminium > 99% **Al** Aluminium Alloy **Al** Aluminium Cast **Cu** Copper **Plastic** Thermo-plast **GG(G)**

Example: Order-N°.		Article-N°.		a-Code							E11970	
		E11970 034										
Ø Code	d	P	L	l	l ₁	d ₂	a					
034	EGM 2	0.40	50	9.00	15.0	2.8	2.1	2	2.15	●		
040	EGM 2.5	0.45	56	12.00	18.0	3.5	2.7	3	2.65	●		
044	EGM 3	0.50	63	13.00	21.0	4.5	3.0	3	3.15	●		
058	EGM 4	0.70	70	15.00	25.0	6.0	4.9	3	4.20	●		
084	EGM 5	0.80	80	17.00	30.0	6.0	4.9	3	5.25	●		
088	EGM 6	1.00	90	20.00	35.0	8.0	6.2	3	6.30	●		
160	EGM 8	1.25	100	22.00	39.0	10.0	8.0	3	8.40	●		

Example: Order-N°.		Article-N°.		a-Code							E11971	
		E11971 174										
Ø Code	d	P	L	l	l ₁	d ₂	a					
174	EGM 10	1.50	110	24.00	40.0	9.0	7.0	3	10.40	●		
240	EGM 12	1.75	110	26.00	40.0	11.0	9.0	3	12.50	●		
244	EGM 14	2.00	110	27.00	40.0	12.0	9.0	4	14.50	●		
246	EGM 16	2.00	125	30.00	65.0	14.0	11.0	4	16.50	●		

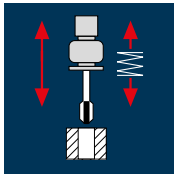
Application**Material**

Steel
< 500 N/mm²



Steel
< 500 N/mm²



Steel
500 - 850 N/mm²



Steel
500 - 850 N/mm²



Wrought aluminium alloys
Si < 6%
hardened



Wrought aluminium alloys
Si < 6%
hardened



Unalloyed copper



Unalloyed copper



EG-M	d [mm]	P [mm]	v _c 1.5 x d			v _c 2.0 x d			v _c 3.0 x d		
			n [min ⁻¹]	v _f [100%]		n [min ⁻¹]	v _f [100%]		n [min ⁻¹]	v _f [100%]	
EGM 2	2.520	0.40	14	1770	708	12	1515	606	10	1265	506
EGM 2.5	3.084	0.45	14	1445	650	12	1240	558	10	1030	464
EGM 3	3.650	0.50	14	1220	610	12	1045	523	10	870	435
EGM 4	4.910	0.70	14	910	637	12	780	546	10	650	455
EGM 5	6.040	0.80	14	740	592	12	630	504	10	525	420
EGM 6	7.300	1.00	14	610	610	12	525	525	10	435	435
EGM 8	9.624	1.25	14	465	581	12	395	494	10	330	413
EGM 10	11.948	1.50	14	375	563	12	320	480	10	265	398
EGM 12	14.274	1.75	14	310	543	12	270	473	10	225	394
EGM 14	16.598	2.00	14	270	540	12	230	460	10	190	380
EGM 16	18.598	2.00	14	240	480	12	205	410	10	170	340
EGM 2	2.520	0.40	10	1265	506	8	1010	404	6	760	304
EGM 2.5	3.084	0.45	10	1030	464	8	825	371	6	620	279
EGM 3	3.650	0.50	10	870	435	8	700	350	6	525	263
EGM 4	4.910	0.70	10	650	455	8	520	364	6	390	273
EGM 5	6.040	0.80	10	525	420	8	420	336	6	315	252
EGM 6	7.300	1.00	10	435	435	8	350	350	6	260	260
EGM 8	9.624	1.25	10	330	413	8	265	331	6	200	250
EGM 10	11.948	1.50	10	265	398	8	215	323	6	160	240
EGM 12	14.274	1.75	10	225	394	8	180	315	6	135	236
EGM 14	16.598	2.00	10	190	380	8	155	310	6	115	230
EGM 16	18.598	2.00	10	170	340	8	135	270	6	105	210
EGM 2	2.520	0.40	11	1390	556	9	1135	454	7	885	354
EGM 2.5	3.084	0.45	11	1135	511	9	930	419	7	720	324
EGM 3	3.650	0.50	11	960	480	9	785	393	7	610	305
EGM 4	4.910	0.70	11	715	501	9	585	410	7	455	319
EGM 5	6.040	0.80	11	580	464	9	475	380	7	370	296
EGM 6	7.300	1.00	11	480	480	9	390	390	7	305	305
EGM 8	9.624	1.25	11	365	456	9	300	375	7	230	288
EGM 10	11.948	1.50	11	295	443	9	240	360	7	185	278
EGM 12	14.274	1.75	11	245	429	9	200	350	7	155	271
EGM 14	16.598	2.00	11	210	420	9	175	350	7	135	270
EGM 16	18.598	2.00	11	190	380	9	155	310	7	120	240
EGM 2	2.520	0.40	12	1515	606	10	1265	506	8	1010	404
EGM 2.5	3.084	0.45	12	1240	558	10	1030	464	8	825	371
EGM 3	3.650	0.50	12	1045	523	10	870	435	8	700	350
EGM 4	4.910	0.70	12	780	546	10	650	455	8	520	364
EGM 5	6.040	0.80	12	630	504	10	525	420	8	420	336
EGM 6	7.300	1.00	12	525	525	10	435	435	8	350	350
EGM 8	9.624	1.25	12	395	494	10	330	413	8	265	331
EGM 10	11.948	1.50	12	320	480	10	265	398	8	215	323
EGM 12	14.274	1.75	12	270	473	10	225	394	8	180	315
EGM 14	16.598	2.00	12	230	460	10	190	380	8	155	310
EGM 16	18.598	2.00	12	205	410	10	170	340	8	135	270